

ORDER INFORMATION

Specification:

1. Rating : DC 16V 5A;
2. Contact resistance: $\leq 30m\Omega$;
After test: $\leq 50m\Omega$
3. Insulation resistance: $\geq 100M\Omega$ (500VDC);
After test: $\geq 50M\Omega$
4. Withstand voltage: 500VAC ;
5. Insertion and extraction force: 3N~30N;
6. life test: 5000cycles min;
7. Operation temperature range: $-20^{\circ}C \sim 70^{\circ}C$
8. Preservative temperature range: $-40^{\circ}C \sim 85^{\circ}C$

5 D J X X D C 0 2 - X X T 0 B L B - 0 1

PIN (Dim.A)
20 ϕ 2.00
24 ϕ 2.35
25 ϕ 2.50

No. of Pin(02~03)

T0: Tin 100u"

B: Black

L: RoHS+PBT

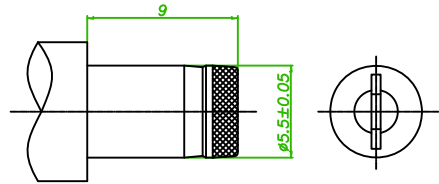

PIN	$\phi 2.0$	$\phi 2.35$	$\phi 2.5$
PLUG	$2.05^{+0.1}$	$2.40^{+0.1}$	$2.55^{+0.1}$

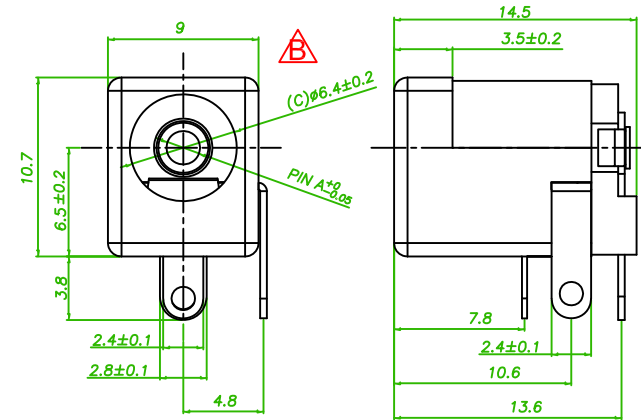

Recommended PCB Layout (PCB TOLERANCE ± 0.05)

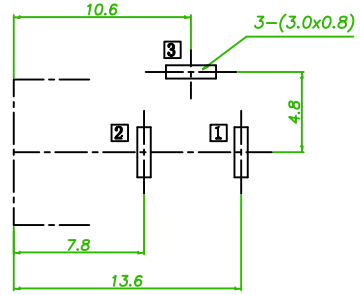
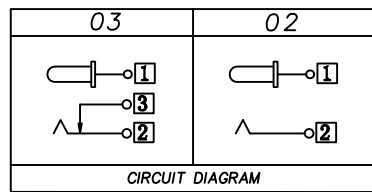

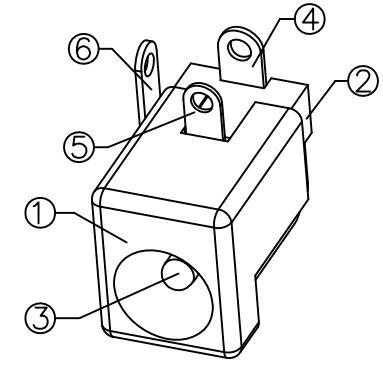
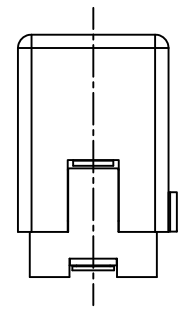

RECOMMENDED P.C.B. LAYOUT
UNSPECIFIED TOLERANCE: ± 0.05
(BOTTOM VIEW)



NO.	DESCRIPTION	QTY	MATERIAL	REMARK
⑥	Shunt terminal	3	1 Brass t=0.40	Tin plating
⑤	Tip spring	2	1 Phosphor bronze t=0.3	Tin plating
④	Center pin terminal	1	1 Brass t=0.40	Tin plating
③	Center pin	1	1 Brass	Tin plating
②	Cover	1	1 PBT	White/Black
①	Housing	1	1 PBT	White/Black

Old Part No. :DCJXX-0014TB-XX-L

 Amtek Technology Co., Ltd. TEL: 886-2-2260-6878 FAX: 886-2-2260-8030	品名 TITLE	DC POWER JACK			頁數 Page	1/1
	品號 PART NO.	5DJXXDC02-XXT0BLB-01			繪圖 DRAWN	Erin 2015/09/23
	圖號 DRAWING NO.	版本 REV.	B	核對 CHECKED	John 2015/09/23	
	客戶品號 CUSTOMER P/N	比例 SCALE	None	承認 APPROVED	John 2015/09/23	
	公差 TOLERANCE	.X \pm 0.50 .XX \pm 0.30	.X* \pm 5	單位 UNIT	mm	THIRD ANGLE PROJECTION

REV.	ECN NO. OR DESCRIPTION	REVISED	DATE
	1. Revised the Drawing 2. Revised the Order information 5DJXXDC09-XXT0BLB-01->5DJXXDC02-XXT0BLB-01	B	2016/10/25 Mia