

Specifications

Current Rate:2 AMP
 Insulation Resistance:1000M Ω Min.
 Contact Resistance:20m Ω Max.
 Dielectric voltage:500V AC for one minute
 Operation Temperature:-40°C to +105 °C

Material

Insulator:Polyester, UL 94V-0
 ◎Standard:P.B.T
 Terminal:Copper Alloy

ORDER INFORMATION

P H 2 D 1 5 - 1 X X B A/L1/B - L

◎Standard Recommend

| | | | | | |
|------------------------------------|---------------|-------------|-------------------|---|----------------|
| No. of contacts per row (02-40) | ◎G:Gold Flash | S:Selective | E:Black Insulator | Fill in Dimension For Special Design | L:RoHS + P.B.T |
| | GA:50" | SA:50" | | | |
| | GR:100" | SR:100" | | | |
| | GC:200" | SC:200" | | | |
| | GD:300" | SD:300" | | | |
| | T:Tin Plated | | | | |
| | TE:Tin 200u" | | | | |

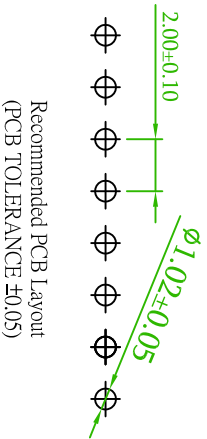
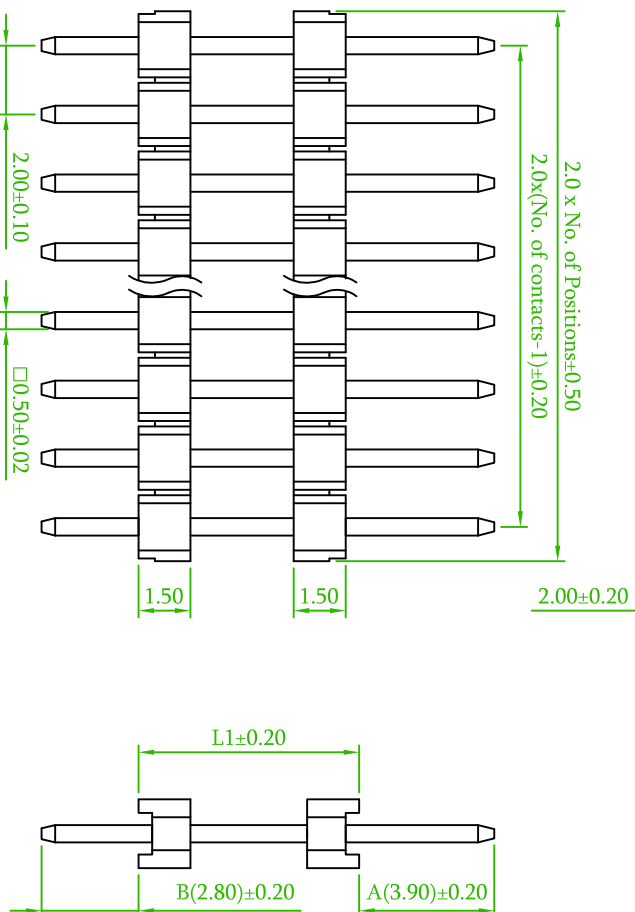
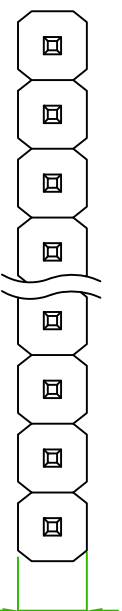

Recommended PCB Layout
 (PCB TOLERANCE ±0.05)

| | | | | |
|--|--|------|-------------|------|
| AREA | | REV. | DESCRIPTION | DATE |
| <p>品名 TITLE PIN HEADER 2.0mm STACK STRAIGHT TYPE</p> <p>品號 PART NO. PH2D15-1XX-L</p> <p>圖號 DRAWING NO. PH2D15-1XX-L</p> <p>客戶品號 CUSTOMER P/N .X ±0.25 .XX ±0.20</p> <p>公差 TOLERANCE</p> <p>單位 UNIT mm</p> <p>日期 DATE 2010/11/24</p> <p>繪圖 DRAWN Joe</p> <p>核對 CHECKED</p> <p>核准 APPROVED James</p> | | | | |

輝德企業有限公司
 Amitek Technology Co., Ltd.
 TEL: 86-2-2266-8055
 FAX: 86-2-2266-8055

