

深圳市福浪电子有限公司  
FRONTER ELECTRONICS CO., LTD.

APPROVAL  
SHEET



(Seam Type)

CUSTOMER: TRG Components AB  
DESCRIPTION: SMD3225 12.000MHz Quartz Crystal Resonator  
MANUFACTURER PART NO.: FTX12.000M20SM3S  
CUSTOMER PART NO.:  
USED IN MODEL :  
REVISION A1

承 认 APPROVAL		
工程部 TECHNOLOGY DEPT.	品质部 QUALITY DEPT.	采购部 PURCHASING DEPT.

Date: March 17, 2014



深圳市福浪电子有限公司

FRONTER ELECTRONICS CO., LTD

地址 ADD: 深圳市福田区深圳大道 6021 号喜年中心 1112~1117 室  
RM.1112-1117, 11/F., XINIAN CENTER, NO.6021, SHENNAN RD.,  
SHENZHEN, CHINA.518040

电话 TEL: 86-755-83458798 传真 FAX: 86-755-83459818

网址 WEB ADD: <http://www.chinafronter.com>

E-MAIL:Kingslin@chinafronter.com

<u>Rev</u>	<u>Revise page</u>	<u>Revise contents</u>	<u>Date</u>	<u>Ref.No.</u>	<u>Reviser</u>
A1	ALL	Initial released		N/A	DavidJiang

**FRONTER ELECTRONICS CO., LTD.**

<b>DESCRIPTION</b>	SMD3225 12.000MHz ±30ppm 20pF	<b>Page:</b>
<b>DATE</b>	2014-03-17	2 / 11

# 1. QUARTZ CRYSTAL UNIT SPECIFICATION

- 1.1 Frequency: 12.000MHz
- 1.2 Holder type : FTX321S (SMD3225 Seam Type)
- 1.3 Mode of oscillation: Fundamental
- 1.4 Frequency tolerance:  $\pm 30\text{ppm}$  at  $25^{\circ}\text{C} \pm 3^{\circ}\text{C}$
- 1.5 Equivalent resistance: 80ohms max
- 1.6 Operating temperature range:  $-20^{\circ}\text{C}$  To  $+70^{\circ}\text{C}$
- 1.7 Storage temperature range:  $-40^{\circ}\text{C}$  To  $+85^{\circ}\text{C}$
- 1.8 Frequency Stability:  $\pm 30\text{ppm}$  at  $-20^{\circ}\text{C}$  To  $+70^{\circ}\text{C}$
- 1.9 Loading capacitance (CL) : 20pF
- 1.10 Drive level: 10 uW Typical (300uW max)
- 1.11 Shunt Capacitance: 2.0pF max
- 1.12 Insulation resistance : More than 500M $\Omega$  at DC 100V
- 1.13 Circuit: Measured in HP/E5100A,S&A 250B
- 1.14 Aging:  $\pm 2$  ppm Max (+25 $^{\circ}\text{C}$  1<sup>st</sup> Year)
- 1.15 Dimensions and marking Refer to page.3
- 1.16 Emboss carrier tape & reel Refer to page.5 and page.6
- 1.17 Note:

## Standard atmospheric conditions

Unless otherwise specified, the standard range of atmospheric conditions for making measurement and tests are as follow:

Ambient temperature :  $25 \pm 3^{\circ}\text{C}$

Relative humidity : 40%~70%

## FRONTER ELECTRONICS CO., LTD.

DESCRIPTION	SMD3225 12.000MHz $\pm 30\text{ppm}$ 20pF	Page:
DATE	2014-03-17	3 / 11

## 2. FTX321S MARKING & DIMENSIONS

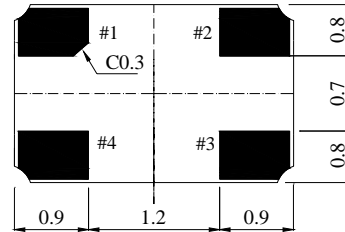
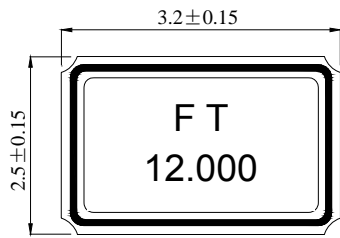

Marking #2, #4 is connected with metal cap of top.

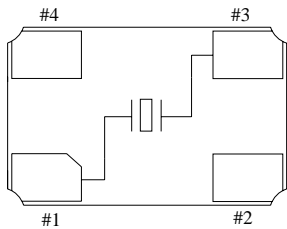

<TOP VIEW>

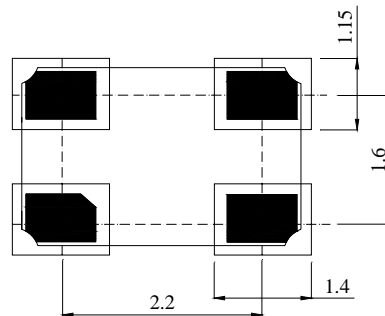

Recommended Solder Pad Layout:

\*Marking should be printed as following:

Logo, Nominal Frequency

\*Manufacturing Logo: FT

\*Nominal frequency = 3 number after decimal point MAX.

( ex. 12.000 MHz → 12.000 )

Marking: Laser marking

### FRONTER ELECTRONICS CO., LTD.

DESCRIPTION	SMD3225 12.000MHz ±30ppm 20pF	Page:
DATE	2014-03-17	4 / 11

### 3. INSIDE STRUCTURE

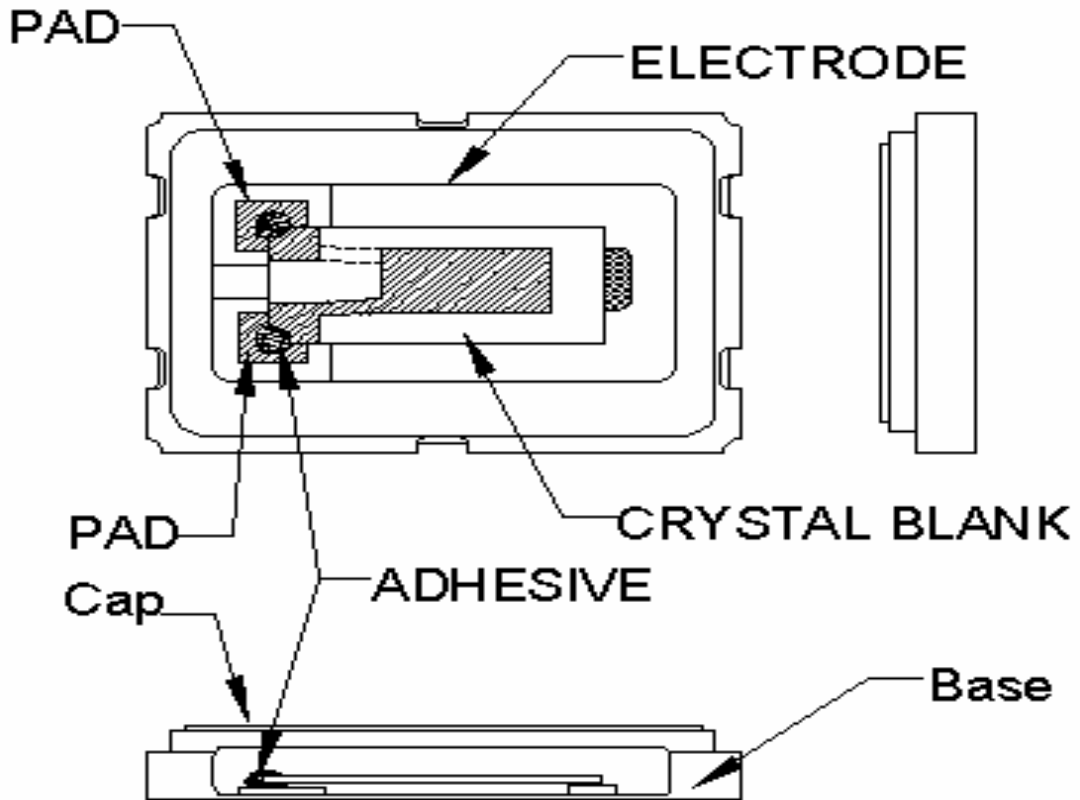

Reference drawing

Base:	Alumina Ceramic ( $Al_2O_3$ ) Metallized Pad: W Ni Plating Au Plating
Cap:	Fe-Ni
(3) Crystal Enclosure Seal:	Seal Seam
(4) Crystal Blank	Rectangular At-Cut Quartz Crystal Blank
(5) Adhesive	Silver Conductive Polyimide Resin
(6) Electrode	Ag
(7) PAD	Alumina Ceramic (W. Ni. Au)

#### FRONTER ELECTRONICS CO., LTD.

DESCRIPTION	SMD3225 12.000MHz $\pm 30$ ppm 20pF	Page:
DATE	2014-03-17	5 / 11

## 4. FTX321S EMBOSS CARRIER TAPE & REEL

a.) Dimensions of Carrier Tape

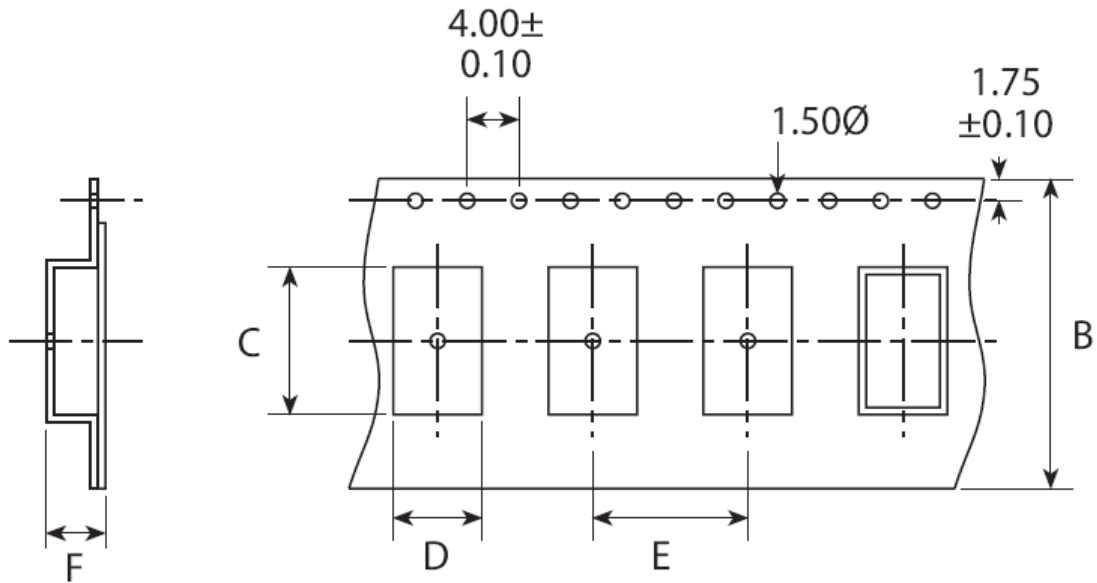

	A	B	C	D	E	F	G
SMD3225	178 ± 2.0	8.0 ± 0.3	3.55 ± 0.10	2.80 ± 0.10	4.0 ± 0.1	0.85 ± 0.10	60.5 ± 1.0

(UNIT: mm)

b.) Dimensions of Reel

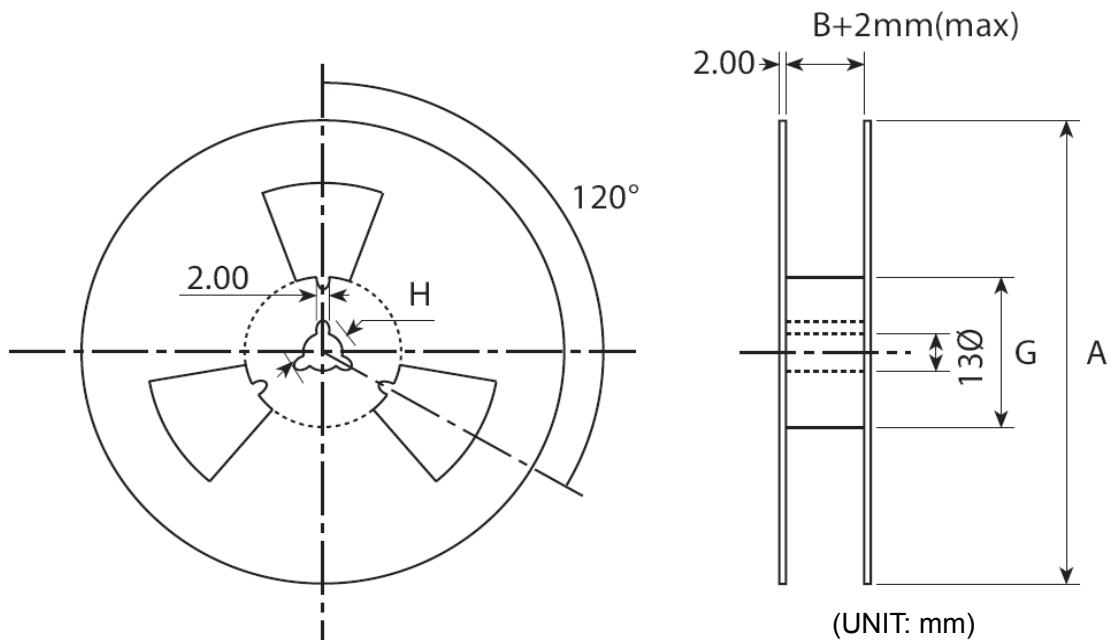

(UNIT: mm)

### FRONTER ELECTRONICS CO., LTD.

<b>DESCRIPTION</b>	SMD3225 12.000MHz ±30ppm 20pF	Page:
<b>DATE</b>	2014-03-17	6 / 11

c.) Storage condition

Temperature: +40deg.C Max.

Relative Humidity: 80% Max.

d.) Standard packing quantity

3,000PCS / REEL

e.) Material of the tape

Tape	Material
Carrier tape	A – PET
Top tape	Polyester

f.) Label contents

.The type of product

.Our specification No.

.Your Part No.

.Lot No.

.Nominal Frequency

.Quantity

.Our Company Name

Sticks label for every reel.

PART NUMBER	
PO NO	
PR. NO:	
HOLDER TYPE	
FREQUENCY	
REMAKS	
QUANTITY	
<b>FRONTER ELECTRONICS CO.,LTD.</b>	

**FRONTER ELECTRONICS CO., LTD.**

<b>DESCRIPTION</b>	SMD3225 12.000MHz ±30ppm 20pF	Page:
<b>DATE</b>	2014-03-17	7 / 11

g.) Taping dimension

Leader	Cover-tape	The length of cover-tape in the leader is more than 400 mm including empty embossed area.
	Carrier-tape	After all products were packaged, must remain more than twenty pieces or 400 mm empty area, which should be sealed by cover-tape.
Terminal	Cover-tape	The tip of cover-tape shall be fixed temporary by paper tape and roll around the core of reel one round.
	Carrier-tape	The empty embossed area which are sealed by top cover-tape must remain more the 40 mm.

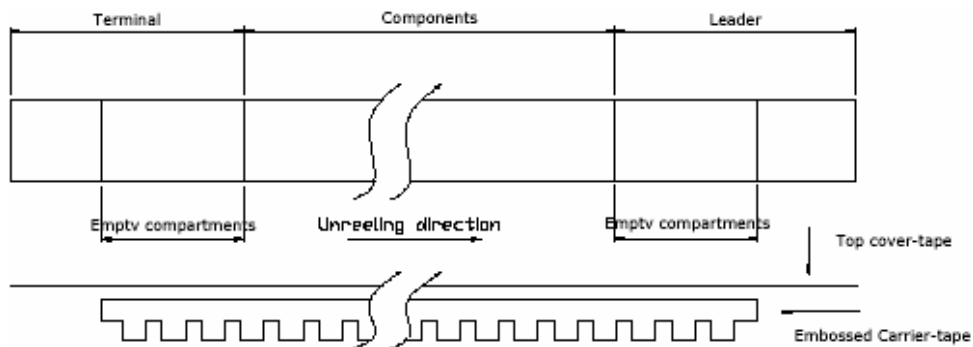

h.) Joint of tape

The carrier-tape and top cover-tape should not be jointed.

i.) Release strength of cover tape

It has to between 0.1N to 0.7N under following condition.

Pulling direction 165° to 180°

Speed 300mm/min.

Otherwise unless specified.

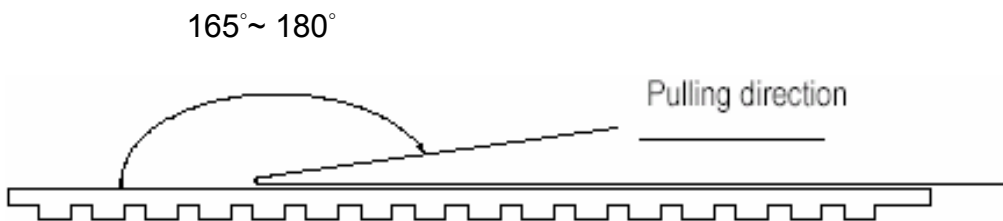

Other standards shall be based on JIS C 0806-1990.

FRONTER ELECTRONICS CO., LTD.		
DESCRIPTION	SMD3225 12.000MHz ±30ppm 20pF	Page:
DATE	2014-03-17	8 / 11



5. Mechanical Endurance: Provided that measurement shall be carried out after letting it alone in the room temperature for 1 hour.

	Item	Conditions	Specifications
5.1	Drop	Method: fallen on the concrete (thickness is 3cm or more) Height: 75 cm Direction: each direction of 3 mutually perpendicular ( x, y, z ) axis. Number of shocks: 2 shocks in each direction	Freq. Drift $\pm$ 5ppm Max Resistance Drift $\pm$ 15% Max
5.2	Vibration	Should be satisfied after supplying following vibration. (1)Vibration Frequency: 10~55Hz (2)Cycle: 1 to 2 Min. (3)Full Cycle: 1.5mm P-P. (4)Direction: X.Y.Z (5)Time: 2 Hours / Each Direction	Freq. Drift $\pm$ 5ppm Max Resistance Drift $\pm$ 15% Max
5.3	Substrate Bending	Mount the specimen on substrate. Apply the following pressure Direction: see Fig -1 Speed: 0.5 mm/sec Hours: 5 $\pm$ 1 sec Amount of substrate: 3 mm Max.	Without mechanical damage such as breaks. Without electrode peeling. Electrical characteristics shall be satisfied.
5.4	Adhesion	Mount the specimen on substrate. Apply the following pressure Direction: see Fig -2 Weight: 10N Hours: 10 $\pm$ 1 sec	
5.5	Body strength	Mount the specimen on substrate. Apply the following pressure Direction: see Fig -3 Weight: 10N Hours: 10 $\pm$ 1 sec	

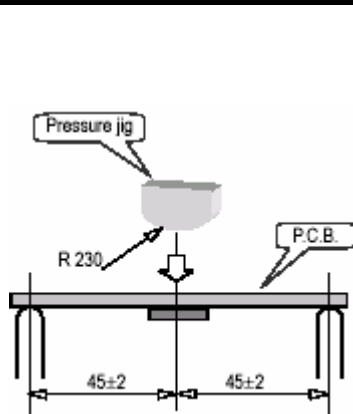

Fig-1

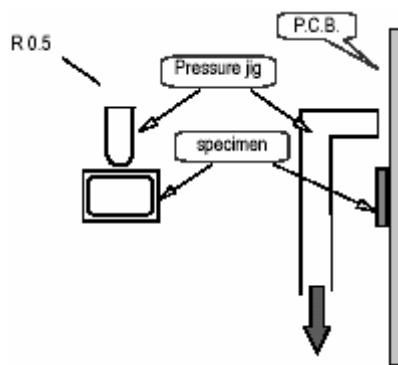

Fig-2

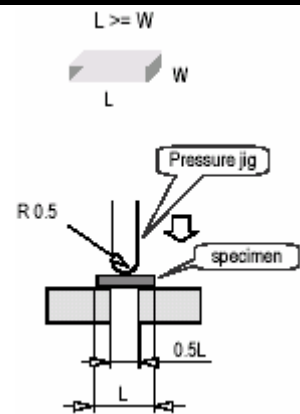
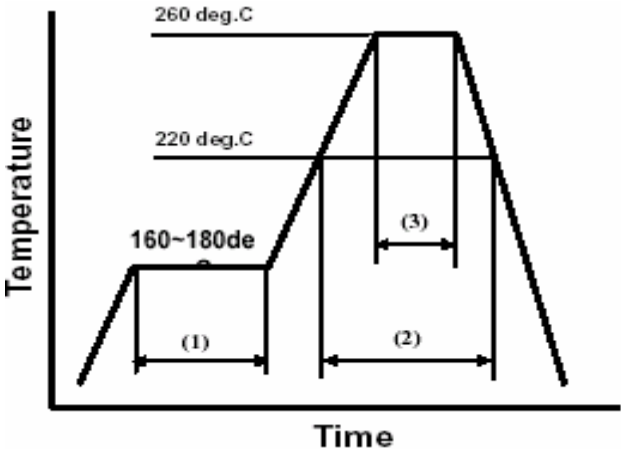

Fig-3

**FRONTER ELECTRONICS CO., LTD.**

DESCRIPTION	SMD3225 12.000MHz $\pm$ 30ppm 20pF	Page:
DATE	2014-03-17	9 / 11

5.6	Seal	Less than $2.0 \times 10^{-9}$ Pa.m <sup>3</sup> /sec by Helium leak detector. Also, no serial bubble is observed by Fluorinate tests.													
5.7	Solder ability	3 sec Dip in $235^{\circ}\text{C} \pm 5^{\circ}\text{C}$ solder. (Use ROSIN type flux for solder.)	More than 90% of lead shall be covered by new solder.												
5.8	Resistance to Soldering Heat	<p>Run in Reflow Reflow soldering shall be allowed Only two(2) time.</p> <p style="text-align: center;"><b>Available for Lead Free Soldering</b></p>  <table border="1" data-bbox="450 1232 1010 1355"> <tr> <td>(1)</td> <td>Preheat</td> <td>160~180 deg.C</td> <td>120sec.</td> </tr> <tr> <td>(2)</td> <td>Primary heat</td> <td>220 deg.C</td> <td>60sec.</td> </tr> <tr> <td>(3)</td> <td>Peak</td> <td>260 deg.C</td> <td>10sec. Max.</td> </tr> </table> <p style="text-align: right;">Freq. Drift <math>\pm 10\text{ppm Max.}</math> Resistance Drift <math>\pm 20\% \text{ Max.}</math></p>		(1)	Preheat	160~180 deg.C	120sec.	(2)	Primary heat	220 deg.C	60sec.	(3)	Peak	260 deg.C	10sec. Max.
(1)	Preheat	160~180 deg.C	120sec.												
(2)	Primary heat	220 deg.C	60sec.												
(3)	Peak	260 deg.C	10sec. Max.												

**FRONTER ELECTRONICS CO., LTD.**

<b>DESCRIPTION</b>	SMD3225 12.000MHz $\pm 30\text{ppm}$ 20pF	Page:
<b>DATE</b>	2014-03-17	10 / 11

6. Environmental Endurance: Provided that measurement shall be carried out after letting it alone in the room temperature for 1 hour.

	Item	Conditions	Specifications
6.1	Humidity	Should be satisfied after letting it alone at $+40^{\circ}\text{C}\pm 2^{\circ}\text{C}$ in humidity of 90%~95% for 500 hours.	Freq. Drift $\pm 5\text{ppm}$ Max Resistance Drift $\pm 15\%$ Max
6.2	Storage in Low Temperature	Should be satisfied after letting it alone at $-40^{\circ}\text{C}\pm 3^{\circ}\text{C}$ for 500 hours.	Freq. Drift $\pm 5\text{ppm}$ Max Resistance Drift $\pm 15\%$ Max
6.3	Storage in High Temperature	Should be satisfied after letting it alone at $+85^{\circ}\text{C}\pm 3^{\circ}\text{C}$ for 500 hours.	Freq. Drift $\pm 5\text{ppm}$ Max Resistance Drift $\pm 15\%$ Max
6.4	Temperature Cycle	Should be satisfied after supplying the following temperature cycle ( 100 cycles). (Refer to Fig-4). Temperature shift from low to high, high to low shall be done in $1^{\circ}\text{C}/\text{min}$ .	Freq. Drift $\pm 5\text{ppm}$ Max Resistance Drift $\pm 15\%$ Max

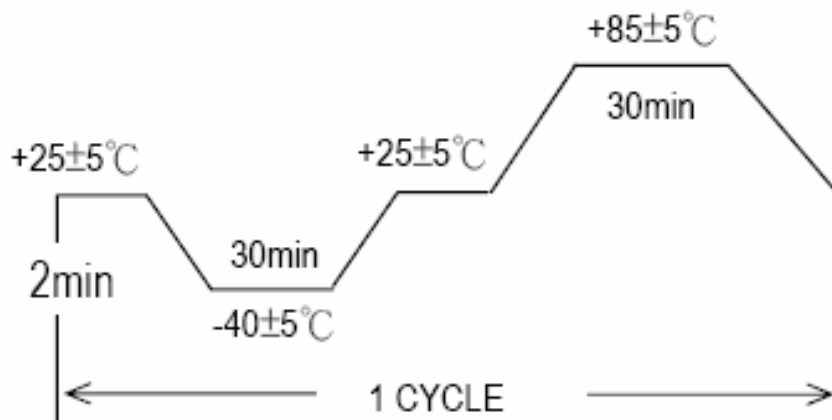

Fig-4

**FRONTER ELECTRONICS CO., LTD.**

DESCRIPTION	SMD3225 12.000MHz $\pm 30\text{ppm}$ 20pF	Page:
DATE	2014-03-17	11 / 11