

深圳市福浪电子有限公司
FRONTER ELECTRONICS CO., LTD

APPROVAL
SHEET



CUSTOMER: TRG
DESCRIPTION: ZTA 4.0MHz CERAMIC RESONATOR
MANUFACTURER PART NO.:
CUSTOMER PART NO: ZTA 4.00MG
USED IN MODEL:

| 承 认 APPROVAL | | |
|-------------------------|----------------------|-------------------------|
| 工程部 TECHNOLOGY DEPT. | 品质部 QUALITY DEPT. | 采购部 PURCHASING DEPT. |
| | | |



深圳市福浪电子有限公司

FRONTER ELECTRONICS CO., LTD

地址 ADD: 深圳市福田区深圳大道 6021 号喜年中心 1112~1117 室

RM.1112-1117, 11/F, XINIAN CENTER, NO.6021, SHENNAN RD.,

SHENZHEN, CHINA.518040

电话 TEL: 86-755-83458798 传真 FAX: 86-755-83459818

网址 WEB ADD: <http://www.chinafronter.com>

E-MAIL: kingslin@chinafronter.com

1. 适用范围 Scope:

本规格书适用于电子振荡器电路用两脚 4.000MHz 陶瓷谐振器。

The specification shall cover of three leads ceramic resonator with 4.000MHz used for oscillation circuit.

2. 规格书号 Spec No: FT-C-ZTA4.00MG-A1

3. 产品型号 Part No: ZTA4.00MG

4. 电气性能 Electrical Characteristics

| NO | 项 目 Items | 规 格 Specification |
|------|---|-------------------------|
| 4-1 | 标称频率 Nominal Frequency | 4.000MHz |
| 4-2 | 频率公差 Frequency Tolerance | ±0.3% max |
| 4-3 | 谐振电阻 Resonant Resistance | 30 Ω max |
| 4-4 | 温度特性 Temperature Stability (-20℃~+80℃) | ±0.3% max |
| 4-5 | 耐高压 Withstanding Voltage | 100V DC 5 sec |
| 4-6 | 最大电压 Max Voltage 直流 DC 交流 AC | 6V DC 15V AC |
| 4-7 | 绝缘电阻 Insulation Resistance | 5*10 ⁸ Ω min |
| 4-8 | 回路电容 Loop Capacitance (C1=C2) | 30PF±20% max |
| 4-9 | 时间老化 10 年 Aging for 10 years | ±0.3% max |
| 4-10 | 工作温度 Operating Temperature | -20℃~+80℃ |
| 4-11 | 储存温度 Storage Temperature | -35℃~+85℃ |

5. 测试: Measurement

5-1 测试条件 Measurement Condition

标准温度应为 25℃±2℃，湿度为 55±5% 的正常大气压。

如无特殊要求，测试可在 5℃~35℃ 的温度范围内，湿度为 45~65% 的条件下进行。

Measurement shall be carried out at the standard temperature of 25±2℃, humidity 55±5% under normal pressure. If no specific requirements, Test can be carried out under 5~35℃, and humidity 45~65%.

5-2 测试电路和设备 Measuring Circuit and Equipment

标称频率应用如图 1 所示的标准测试电路测得，谐振电阻应由网络分析仪测得。

Nominal frequency shall be measured by the standard test circuit as shown in Fig 1, Resonant

Resistance shall be measured by network analyzer.

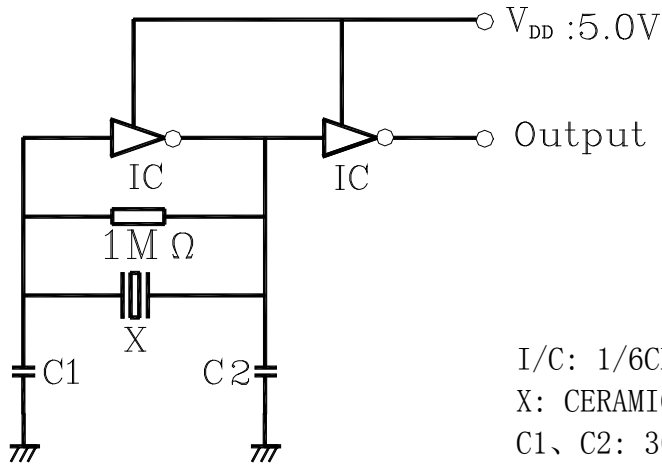

I/C: 1/6CD4069UBEX2
 X: CERAMIC RESONATOR
 C1、C2: 30PF

6. 外形 Outline

6-1 外形: 标志完整清晰, 外表光洁无损伤。

Appearance: Mark shall be clear, appearance shall be smooth and no damage.

6-2 尺寸 Dimensions:

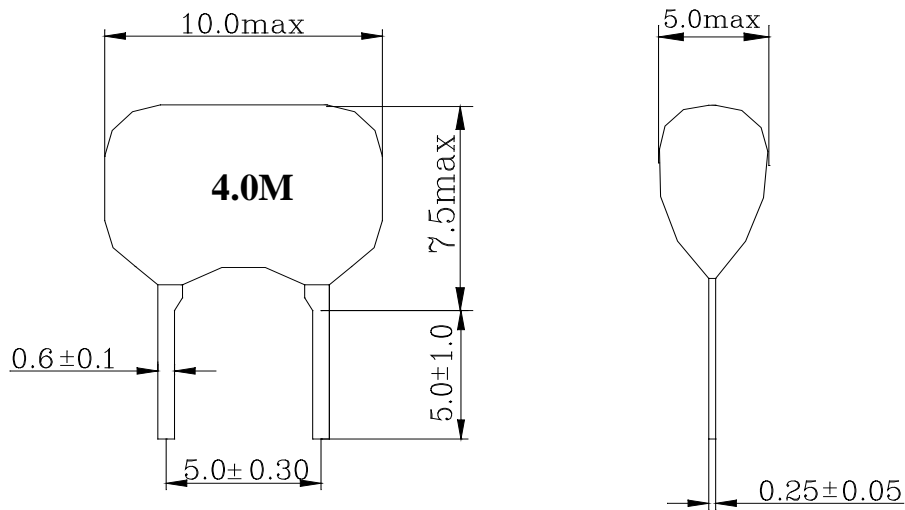

6-3 标志 Marks:

6-4 结构: 单片树脂结构封装。

Structure: Single wafer wrapped by resin.

7. 机械性能 Physical Characteristics

| NO | 测试项目 Item | 测试条件 Measurement condition | 性能要求 Requirement |
|------------|--|---|---|
| 7-1 | 自由跌落 Random Drop | 谐振器从 1.0 米的高度自由落到水泥地面上 3 次后再测试。 Resonator shall be measured after 3 times random drops from the 1.0m on concrete floor. | 没有可见损伤,且测得值满足表 1。 No visible damage and it meet Table 1. |
| 7-2 | 振动 Vibration | 振动幅度为 1.5mm,其振动频率为 10-55Hz。振动沿三个互相垂直的方向进行,各 2 个小时。 Resonator shall be measured after being applied vibration of amplitude of 1.5mm with 10-55Hz band of vibration frequency to each of 3 perpendicular directions for 2 hours. | 没有可见损伤,且测得值满足表 1。 No visible damage and it meet Table 1. |
| 7-3 | 可焊性 Solderability | 引线端子须插入助焊剂中 5 秒,后浸入 230±5℃的焊接槽中 3±0.5 秒。 Lead are immersed in aide solder for 5 sec and then immersed in soldering bath of 230±5℃,for 3±0.5 sec. | 最少 95%的引线脚端子须浸上焊料。 At least 95% lead terminals shall be covered with solder. |
| 7-4 (1) | 端子强度 Terminal strength 拉力试验 Pulling | 在每个端子上沿端子的轴方向作用 1Kg 的拉力 10 秒后对谐振器进行测试。 After force of 1kg for 10 seconds is applied to each terminal in axial direction, Resonator shall be measured. | 无明显损伤,且测得值满足表 1, 没有截断。 No damage ,no cut off and it meet Table 1 |
| 7-4 (2) | 弯曲 Bending | 将引脚端子一齐固定在距谐振器主体 2mm 处,将引脚正方向弯曲距它们的轴方向+90 度,后弯曲-90 度,弯曲的速度分别 3 秒钟。 After lead terminals shall fixed at 2mm from resonator's body ,they shall be folded up to 90°,from their axial directions and folded back to their axial direction, the speed of folding be each 3 seconds. | |

8. 环境性能 Environmental Characteristics

| NO | 测试项目 Item | 测试条件 Measurement | 性能要求 Requirement |
|-----|-----------------------------------|---|--|
| 8-1 | 湿度试验 Humidity | 将谐振器放在相对湿度为 90-95%，温度为+60±2℃ 的湿度箱中 1000 小时，后置于自然环境中 1 小时，再进行测试。 After being placed in a chamber with 90-95%R.H at +60±2℃ for 1000 hours and then being placed in room temperature for 1hour resonator shall be measured. | 测得值必须满足表 1 的要求。 It shall meet Table 1. |
| 8-2 | 耐焊接热 Resistance to Solder Heat | 引线端子应插入 350±10℃的焊接槽中 3±0.5 秒或 260±5℃的焊接槽中 10±15 秒，测入深度为谐振器主体 1.5mm，而后放在自然环境中 1 小时，再进行测试。 Lead terminals are immersed up to 1.5mm from resonator's body in soldering bath of 350±10℃ for 3±0.5 sec. And then resonator shall be measured after being placed in room temperature for 1 hour. | 测得值必须满足表 1 的要求。 It shall meet Table 1. |
| 8-3 | 高温试验 High Temperature | 将谐振器放在+85±2℃的温箱中 1000 小时后置于自然环境中 1 小时，再进行测试。 After being placed in a chamber with +85±2℃ for 1000 hours and then being placed in room temperature for 1 hour ,resonator shall be measured . | 测得值必须满足表 1 的要求。 It shall meet Table 1. |
| 8-4 | 低温试验 Low Temperature | 将谐振器放在-55±2℃的温箱中 1000 小时后，置于自然环境中 1 小时，再进行测试。 After being placed in a chamber with -55±2℃ for 1000 hours and then being placed in room temperature for 1 hour ,resonator shall be measured . | 测得值必须满足表 1 的要求。 It shall meet Table 1.. |
| 8-5 | 热冲击试验 Heat Shock | 将谐振器从室温中取出，置于-55℃的低温中 30 分钟后立即置于+85℃的高温中 30 分钟，然后再回到-55℃的低温中，如此循环 5 次，再将谐振器置于自然环境中 1 小时，再进行测试。 After being kept at room temperature ,resonator shall be placed at temperature of -55℃,for 30 minutes ,then be placed at temperature +85℃,for 30 minutes ,After that returned to -55℃ again. Repeated above cycle for 5 times, After being kept in room temp for 1 hour, resonator shall be measured. | 测得值必须满足表 1 的要求。 It shall meet Table 1. |

表 1 Table 1

| 测试项目 Item | 规格 Specification |
|------------------------------|---------------------|
| ※ 振荡频率 Oscillation Frequency | ±0.3% max |
| 谐振电阻 Resonant Resistance | 30Ω max |

※ 注：从初始值起。

※ Remark: From initial value.