

ELECTRICAL

Standard: UL IEC
 Rated Voltage: 150V 250V
 Rated Current: 4A 5A
 Contact Resistance: 20mΩ
 Insulation Resistance: 500MΩ / DC 500V
 Withstanding Voltage: AC 1250V for one minute
 Wire range: 26~20AWG 0.5mm²

MECHANICAL

Strip Length: 8mm
 Temp. Range: -40°C~+105°C

MATERIAL

Housing: Nylon66, UL94V-0
 Shrapnel: Stainless Steel
 Clip: Phosphor Bronze, Ni plated

ORDER INFORMATION

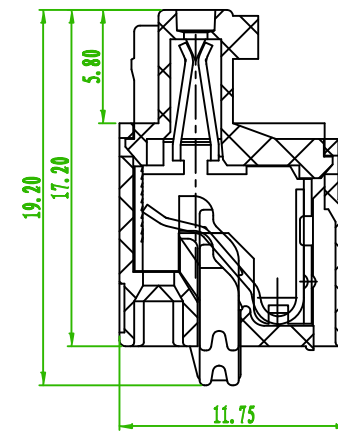
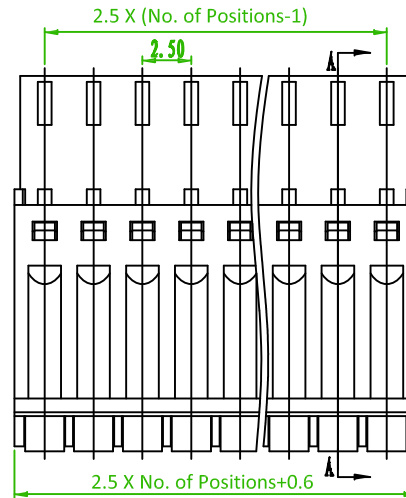
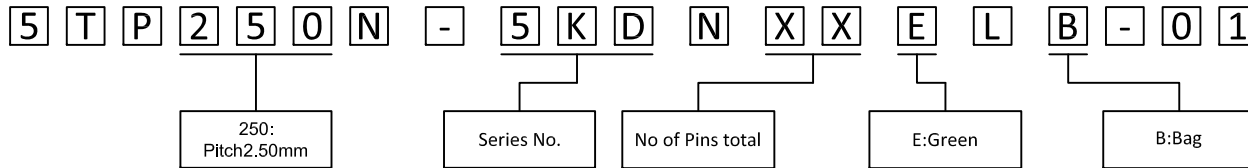

SECTION A-A

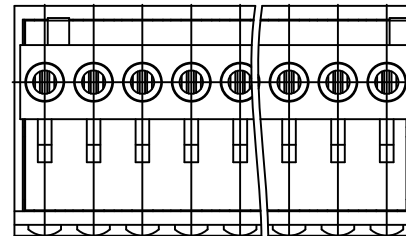

TOLERANCES EXCEPT AS NOTED

	linear dimension				fillet	chamfer	∠ short angle sid			≡	—	□	//	⊥			
	variable range	to	over	over	over	to	to	to	to	to	to	to	to	to			
	6	30	120	480	all	to 6	to 10	to 10	to 10	to 10	to 5	to 30	to 120	to 120			
tolerance	±0.1	±0.2	±0.3	±0.5	±0.9	±0.2	±0.5	±1	1'	30'	20'	10'	0.5	0.025	0.06	0.12	0.4

Old Part No. :TB15EKD-2.5-XXP-14-00A-L

糧德精密有限公司
 Amtek Technology Co., Ltd.
 TEL: 886-2-2260-6878
 FAX: 886-2-2260-8030

品名 TITLE	Terminal Block				頁數 Page	1/1
品號 PART NO.	5TP250N-5KDNXXELB-01				繪圖 DRAWN	Joe 2012/01/03
圖號 DRAWING NO.	GN011-MC315	版本 REV.	A	核對 CHECKED	Shino 2012/01/03	
客戶品號 CUSTOMER P/N		比例 SCALE	None	承認 APPROVED	James 2012/01/03	
公差 TOLERANCE		單位 UNIT	mm	THIRD ANGLE PROJECTION		

REV.	ECN NO. OR DESCRIPTION	REVISED	DATE