

**Harvatek Surface Mount CHIP LEDs Approval Sheet
HT-297USD/NG-8535**

Official Product	HT Part No. HT-297USD/NG-8535	Your Part No.		Data Sheet No.
Tentative Product	*****	*****		
Specifications are subject to changes for improvement without advance notice. Proprietary data, drawings, and company confidential all rights reserved.		10/15/2012	Version of 1.0	Page 1/12

DISCLAIMER..... 3

PRODUCT SPECIFICATION..... 4

ATTENTION: ELECTRICSTATIC DISCHARGE (ESD) PROTECTION..... 4

LABEL SPEC.: 5

PRODUCT SPECIFICATION..... 6

PRODUCT FEATURE..... 7

ELECTRO-OPTICAL CHARACTERISTICS..... 7

PACKAGE OUTLINE DIMENSION AND RECOMMENDED SOLDERING PATTERN FOR REFLOW

SOLDERING 7

ABSOLUTE MAXIMUM RATINGS 7

CHARACTERISTICS OF HT-297 SERIES..... 8

PACKAGING TAPE, REEL, AND PACKING MODEL..... 9

TAPE DIMENSION 9

REEL DIMENSION 9

PACKING MODEL 10

DRY PACK..... 10

CAUTIONS OF PICK AND PLACE..... 11

PRECAUTIONS..... 11

RE-FLOW SOLDERING 11

REWORK..... 12

CLEANING..... 12

CAUTIONS OF PICK AND PLACE 12

REVISE HISTORY 12

Official Product	HT Part No. HT-297USD/NG-8535	Your Part No.		Data Sheet No.
Tentative Product	*****	*****		
Specifications are subject to changes for improvement without advance notice. Proprietary data, drawings, and company confidential all rights reserved.		10/15/2012	Version of 1.0	Page 2/12

DISCLAIMER

HARVATEK reserves the right to make changes without further notice to any products herein to improve reliability, function or design. HARVATEK does not assume any liability arising out of the application or use of any product or circuit described herein; neither does it convey any license under its patent rights, nor the rights of others.

LIFE SUPPORT POLICY

HARVATEK's products are not authorized for use as critical components in life support devices or systems without the express written approval of the President of HARVATEK or HARVATEK INTERNATIONAL. As used herein:

1. Life support devices or systems are devices or systems which, (a) are intended for surgical implant into the body, or (b) support or sustain life, and (c) whose failure to perform when properly used in accordance with instructions for use provided in the labeling, can be reasonably expected to result in a significant injury of the user.
2. A critical component in any component of a life support device or system whose failure to perform can be reasonably expected to cause the failure of the life support device or system, or to affect its safety or effectiveness.

Official Product	HT Part No. HT-297USD/NG-8535	Your Part No.		Data Sheet No.
Tentative Product	*****	*****		
Specifications are subject to changes for improvement without advance notice. Proprietary data, drawings, and company confidential all rights reserved.		10/15/2012	Version of 1.0	Page 3/12

Product Specification

	Specification	Material	Quantity
Iv	USD:45.0-180.0 mcd NG: 112.5-360.0 mcd @20mA/ Ta= 25° C Tolerance±10%		
lambda(λ _D)	USD:615.0-630.0 nm NG:520.0-540.0 nm @20mA/ Ta= 25° C Tolerance±0.5nm		
Vf	USD: 1.6-2.4 V NG: 2.7-3.9 V(0.2/BIN) @20mA/ Ta= 25° C		
Ir	< 100 μA @ V _R = 5 V		
Resin	Diffused	Epoxy Resin	
Carrier tape	According to EIA 481-1A specs	Conductive black tape	4000pcs per reel
Reel	According to EIA 481-1A specs	Conductive black	
Label	HT standard	Paper	
Packing bag	220x240mm	Aluminum laminated bag/ no-zipper	One reel one bag
Carton	HT standard	Paper	Non-specified

Others:

Every mid-box will be loaded 5 reels. These 5 reels can be different in lot, Iv, lambda, or Vf. Every reel will have an independent label to identify its specification and the mid-box there will have a corresponding label post on it.

ATTENTION: Electricstatic Discharge (ESD) protection



The symbol shown on the page herein to introduce 'Electro-Optical Characteristics'. ESD protection for GaP and AlGaAs based chips is still necessary even though they are safe in low static-electric discharge. Parts built with AlInGaP, GaN, or/and InGaN based chips are **STATIC SENSITIVE devices**. ESD protection has to considered and taken in the initial design stage.

If manual work/process is needed, please ensure the device is well protected from ESD during all the process.

Official Product	HT Part No. HT-297USD/NG-8535	Your Part No.		Data Sheet No.
Tentative Product	*****	*****		
Specifications are subject to changes for improvement without advance notice. Proprietary data, drawings, and company confidential all rights reserved.		10/15/2012	Version of 1.0	Page 4/12

Label Spec.:

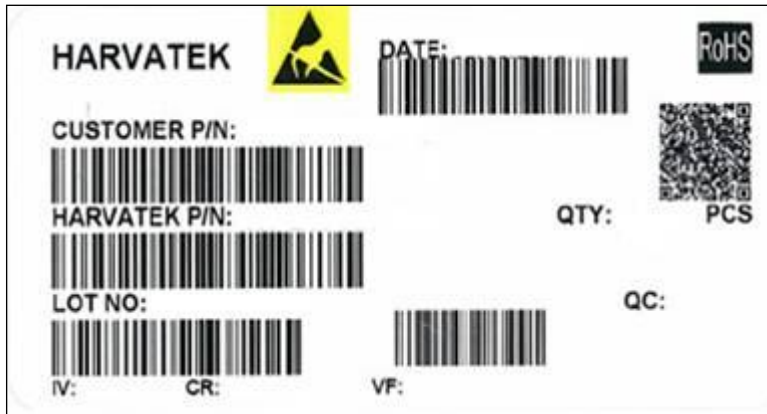

■ Customer P/N: To Be Defined:

HT-297 - USD / NG 8535

Series Name	Emitting Color
HT-297: 1.6x0.8x0.5mm	USD: Ultra Bright Orange @20mA NG: Green @20mA

■ Lot No.

1	2	3	4	5	6	7	8	9	10
E	1	A	1	A	2	2	L	1	2
Code 1 2		Code 3	Code 4	Code 5	Code 6	Code 7	Code 8	Code 9	Code 10
		Mfg. Year	Mfg. Month	Mfg. Date	Consecutive number		Special code		
Internal Tracing Code		2010-A 2011-B 2012-C 2013-D . .	1:Jan. 2:Feb. A:Oct. B:Nov. C:Dec.	1:A 2:B 3:C ... 26:Z 27:7 28:8 29:9 30:3 31:4	01~ZZ		000~ZZZ		

Official Product	HT Part No. HT-297USD/NG-8535	Your Part No.		Data Sheet No.
Tentative Product	*****	*****		
Specifications are subject to changes for improvement without advance notice. Proprietary data, drawings, and company confidential all rights reserved.		10/15/2012	Version of 1.0	Page 5/12

Product Specification

■ Luminous Intensity (Iv) Bin:

Color	Bin Code	Spec. Range
Ultra Bright Orange	P	45.0-71.5 mcd
	Q	71.5-112.5 mcd
	R	112.5-180.0 mcd
Green	R	112.5-180.0 mcd
	S	180.0-285.0 mcd
	T	285.0-360.0 mcd

■ Dominant Wavelength (λ_D) Bin:

Color	Bin Code	Spec. Range
Ultra Bright Orange	--	615.0-630.0 nm
Green	B	520.0-525.0 nm
	C	525.0-530.0 nm
	D	530.0-535.0 nm
	E	535.0-540.0 nm

■ Forward Voltage (Vf) Bin:

Color	Bin Code	Spec. Range
Ultra Bright Orange	--	1.6-2.4 V
Green	G8	2.7-2.9 V
	H7	2.9-3.1 V
	H8	3.1-3.3 V
	J7	3.3-3.5 V
	J8	3.5-3.7 V
	K7	3.7-3.9 V

Official Product	HT Part No. HT-297USD/NG-8535	Your Part No.		Data Sheet No.
Tentative Product	*****	*****		
Specifications are subject to changes for improvement without advance notice. Proprietary data, drawings, and company confidential all rights reserved.		10/15/2012	Version of 1.0	Page 6/12

Product Feature

Electro-Optical Characteristics

(I_F @ 20mA, T_a 25°C)

Code for parts	Lighting Color	Material	V_F (V)		λ (nm)			I_V^* (mcd)
			typ	max	λ_D	λ_P	$\Delta \lambda$	typ
HT-297USD/NG	Ultra Bright Orange	AllnGaP	1.9	2.4	622	636	17	112.5
	Green	InGaP	3.3	3.9	527	520	40	285.0

Package Outline Dimension and Recommended Soldering Pattern for Reflow Soldering

Unit: mm Tolerance: +/-0.1

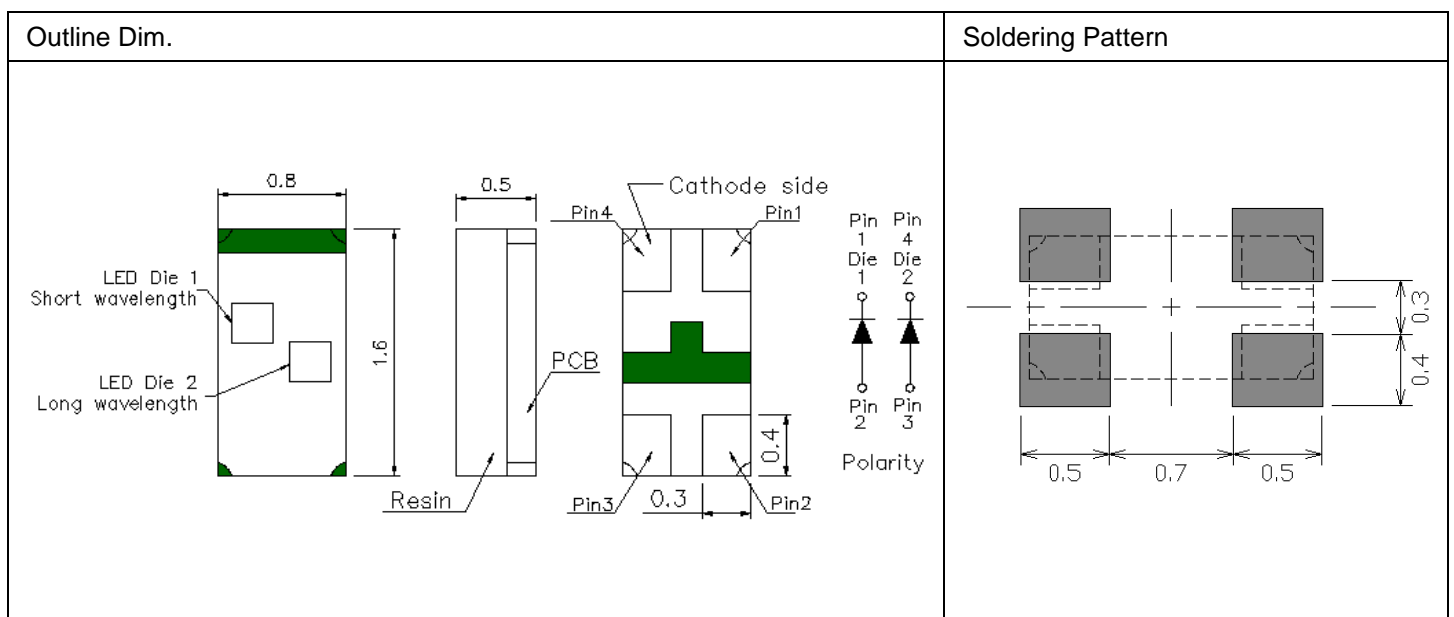

1. Soldering terminal may shift in x, y direction.
2. LED die 1 and LED die 2 can be the same chips.
3. Both dices in the package need to be either P side-up or N side-up.

Absolute Maximum Ratings

(T_a 25°C)

Series	P_d (mW)	I_F (mA)	I_{FP} (mA)	V_R (V)	T_{OP} (°C)	T_{ST} (°C)
HT-297	Ultra Bright Orange	72	30	5	-40~+85	-40~+85
	Green	78	20			

** Condition for I_{FP} is pulse of 1/10 duty and 0.1msec width

** Remarks: This product should be operated in forward bias. If a reverse voltage is continuously applied to the product, such operation can cause migration resulting in LED damage.

Official Product	HT Part No. HT-297USD/NG-8535	Your Part No.		Data Sheet No.
Tentative Product	*****	*****		
Specifications are subject to changes for improvement without advance notice. Proprietary data, drawings, and company confidential all rights reserved.		10/15/2012	Version of 1.0	Page 7/12

Characteristics of HT-297 Series

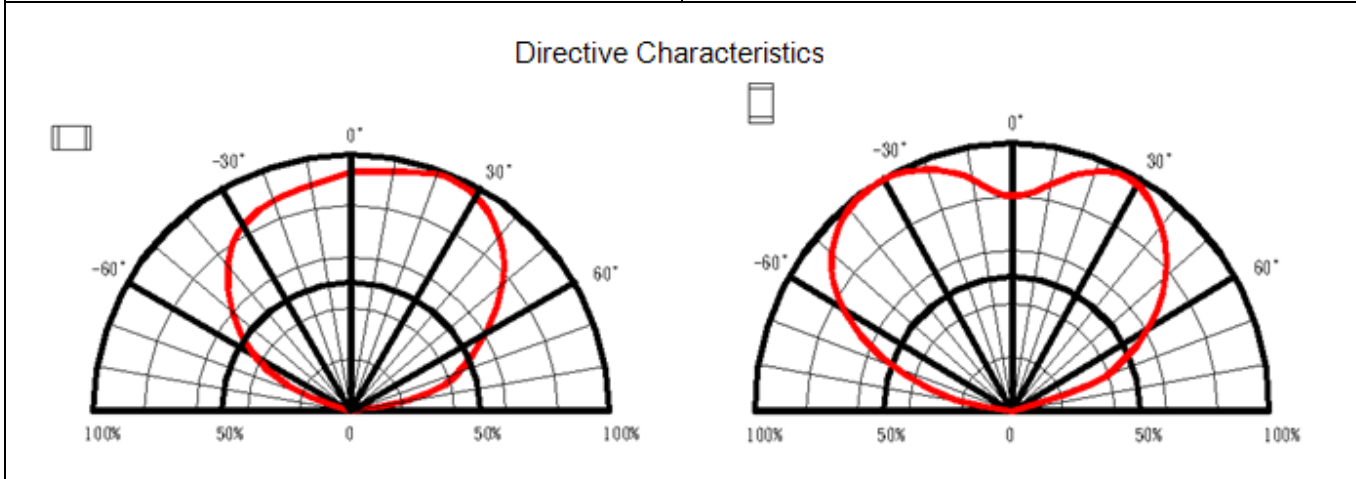
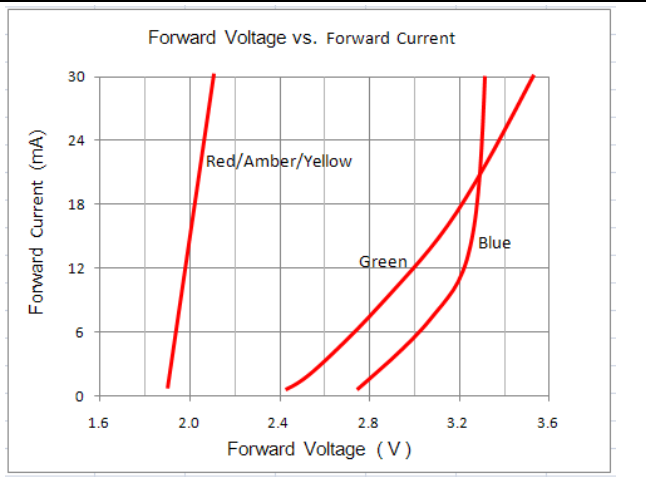
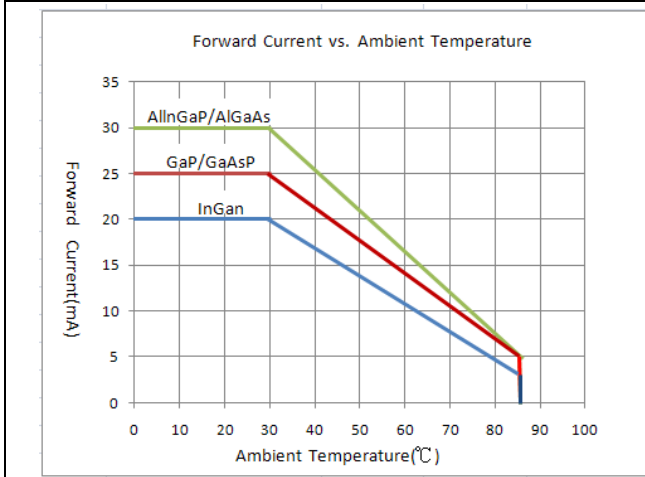
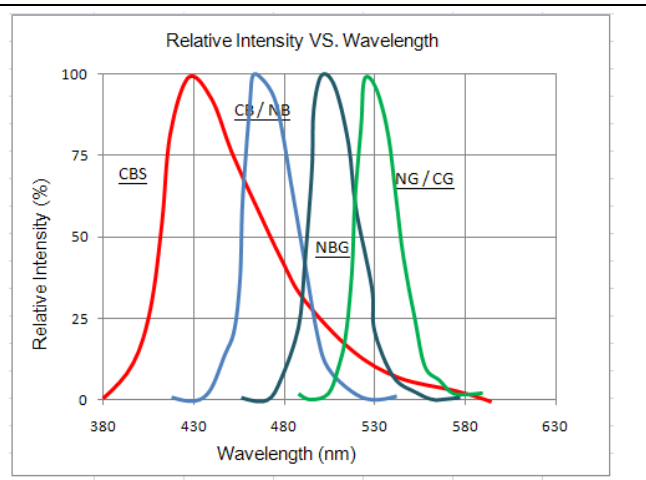
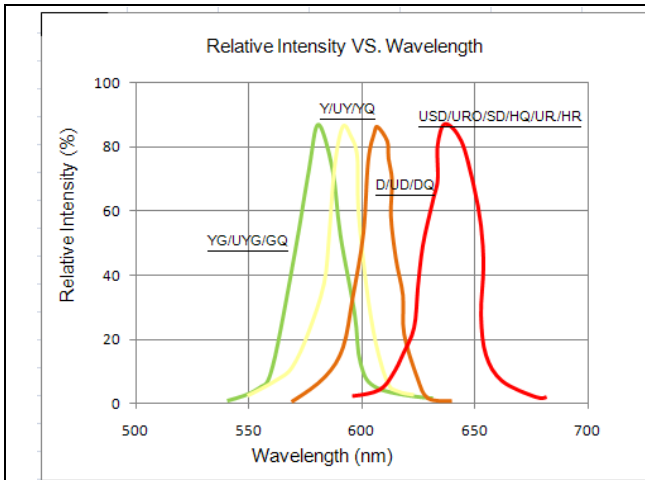

Official Product	HT Part No. HT-297USD/NG-8535	Your Part No.	Data Sheet No.
Tentative Product	*****	*****	
Specifications are subject to changes for improvement without advance notice. Proprietary data, drawings, and company confidential all rights reserved.	10/15/2012	Version of 1.0	Page 8/12

Packaging Tape, Reel, and Packing Model Tape Dimension

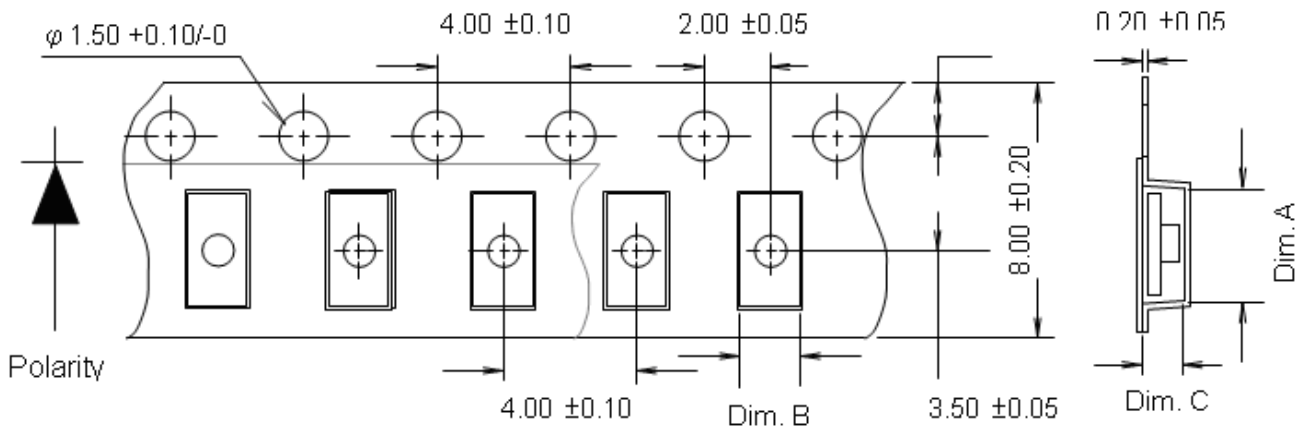

Part No.	Dim. A	Dim. B	Dim. C	Q'ty/Reel
HT-297	1.75 ± 0.10	0.90 ± 0.10	0.60 ± 0.10	4K

Unit: mm

Reel Dimension

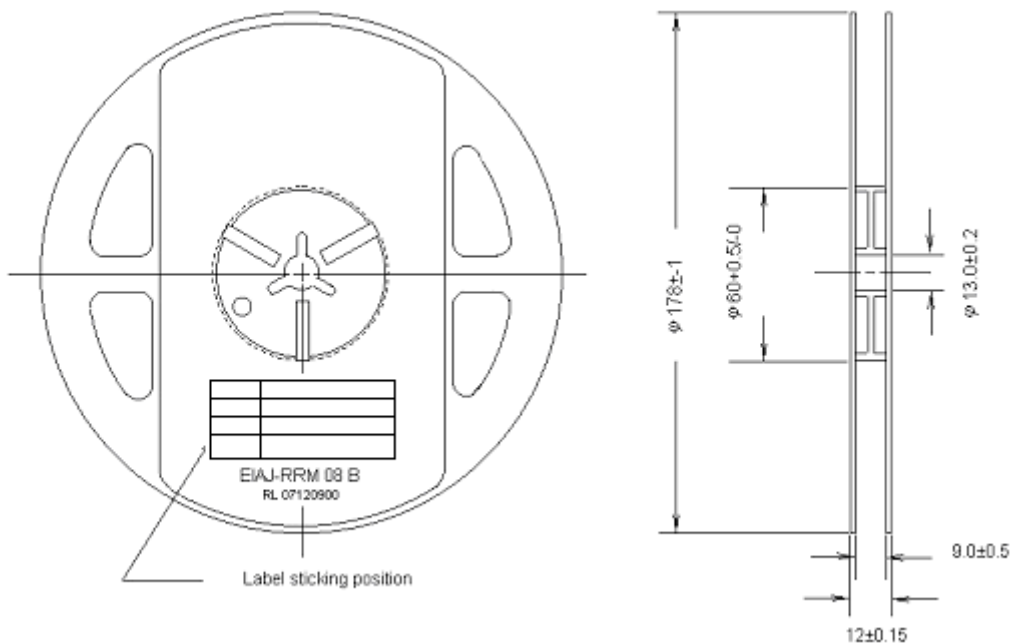

Official Product	HT Part No. HT-297USD/NG-8535	Your Part No.		Data Sheet No.
Tentative Product	*****	*****		
Specifications are subject to changes for improvement without advance notice. Proprietary data, drawings, and company confidential all rights reserved.		10/15/2012	Version of 1.0	Page 9/12

Packing Model

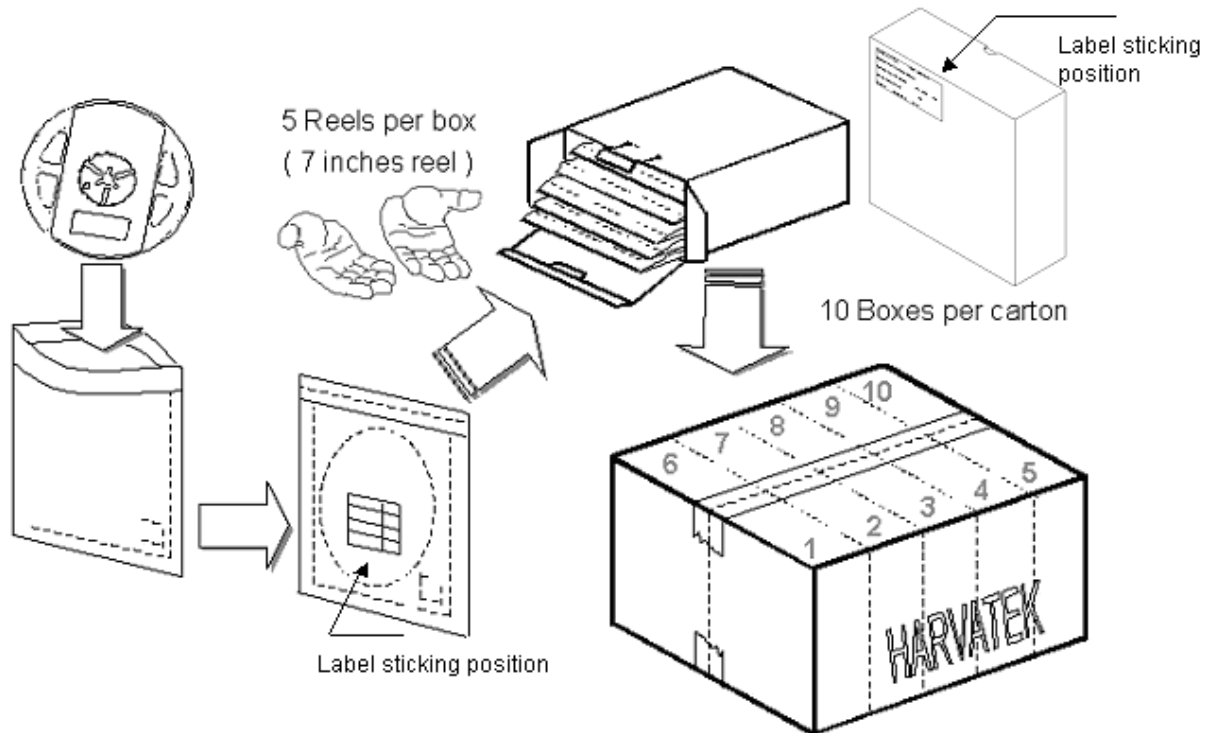

5 boxes per carton is available according to shipping quantity.

Dry Pack

Any SMD optical device, like this chip LED, is **MOISTURE SENSITIVE device**. Avoid absorbing moisture at any time during transportation or storage. Every reel will be packaged in the moisture barrier anti-static bag (Specific bag material will depend upon customers' requirement or option). And the bag is well sealed before shipment.

By customer's requirement, we will put a humidity indicator in each moisture barrier anti-static bag before shipment.

The package is the following:

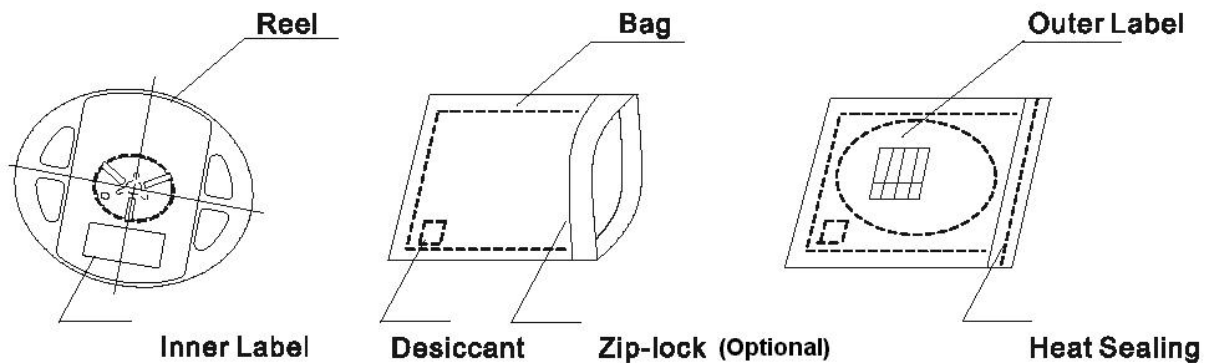

Official Product	HT Part No. HT-297USD/NG-8535	Your Part No.	Data Sheet No.
Tentative Product	*****	*****	
Specifications are subject to changes for improvement without advance notice. Proprietary data, drawings, and company confidential all rights reserved.	10/15/2012	Version of 1.0	Page 10/12

Cautions of Pick and Place

It should be avoided to load stress on the resin during high temperature.

Avoid rubbing or scraping the resin by any object.

Electric-static may cause damage to the component. Please confirm that the equipment grounding well. Using an ionizer fan is recommended.

PRECAUTIONS

1. Avoid absorbing moisture at any time during transportation or storage.
2. Anti-Static process is needed especially when handling GaN, InGaN, and AlInGaP products.
3. It is suggested to connect the unit with a proper series current limit resistor. Avoid driving reverse voltage over the specification of LEDs when turning the unit ON/OFF.
4. Any application should refer to the specifications of absolute maximum ratings.
5. Avoid any direct contact with the viewing area.
6. If possible, assemble the unit in a clean room or dust-free environment.

Re-flow Soldering

Recommend soldering paste specifications:

1. Operating temp.: Above 220 °C ,60 sec.
2. Peak temp.:260 °CMax.,10sec Max.
3. Never attempt next process until the component is cooled down to room temperature after reflow.
4. The recommended reflow soldering profile (measured on the surface of the LED terminal) is as following:

Lead-free Solder Profile

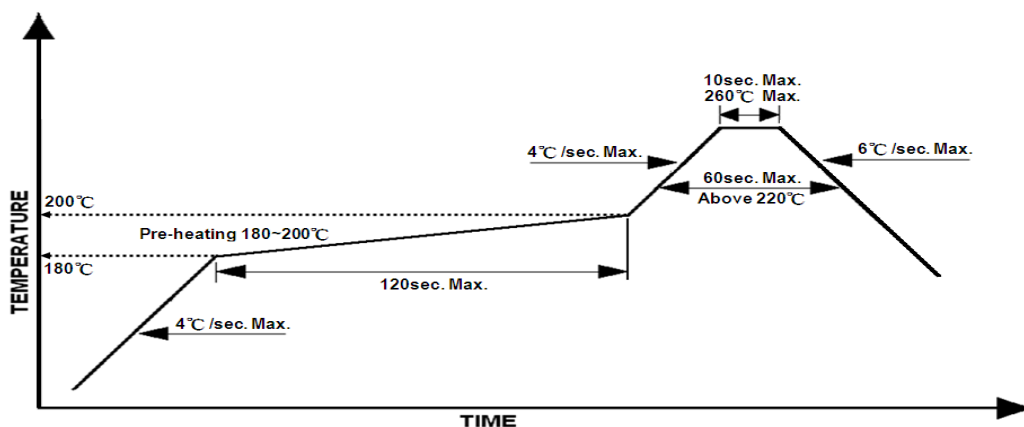

Official Product	HT Part No. HT-297USD/NG-8535	Your Part No.		Data Sheet No.
Tentative Product	*****	*****		
Specifications are subject to changes for improvement without advance notice. Proprietary data, drawings, and company confidential all rights reserved.		10/15/2012	Version of 1.0	Page 11/12

Rework

- ◆ Customer must finish rework within 5 sec. under 260 °C.
- ◆ The head of iron cannot touch copper foil.
- ◆ Twin-head type is preferred.

Cleaning

The conditions of cleaning after soldering:

An alcohol-based solvent such as isopropyl alcohol (IPA) is recommended.

Temperature×Time: <50 °C×30sec, or <30 °C×3min

Ultra sonic cleaning: < 15W/ bath; Bath volume: 1liter max.

Curing: 100 °C max, <3min

Do not contact with component on the assembly board.

Cautions of Pick and Place

It should be avoided to load stress on the resin during high temperature.

Avoid rubbing or scraping the resin by any object.

Electric-static may cause damage to the component. Please confirm that the equipment grounding well. Using an ionizer fan is recommended.

Revise History

Rev.	Descriptions	Date	Page
1.0	-	10/18/2011	
2.0	-	10/15/2012	

Official Product	HT Part No. HT-297USD/NG-8535	Your Part No.		Data Sheet No.
Tentative Product	*****	*****		
Specifications are subject to changes for improvement without advance notice. Proprietary data, drawings, and company confidential all rights reserved.		10/15/2012	Version of 1.0	Page 12/12