

Single DIGIT SMD DISPLAY (0.56")

# LSSD515/6WK-XX

## DATA SHEET

DOC.NO : QW0905- LSSD515/6WK-XX

---

REV. : A

---

DATE : 25 – Nov. – 2013

---

## Package Dimensions

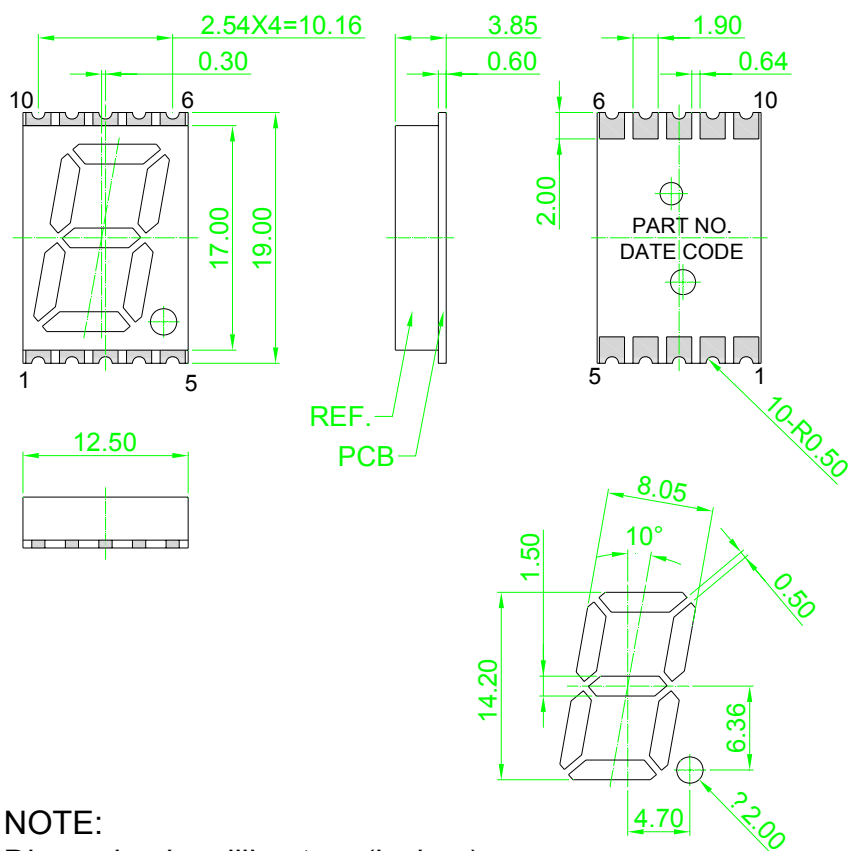

NOTE:  
Dimension in millimeters (inches),  
and tolerances are  $\pm 0.25\text{mm}$  (.01") specified.

## Recommended Soldering Pad Dimensions

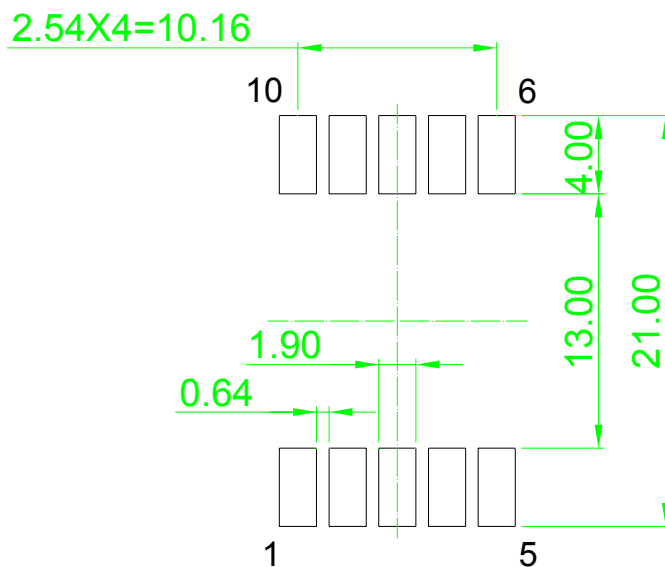

## Internal Circuit Diagram

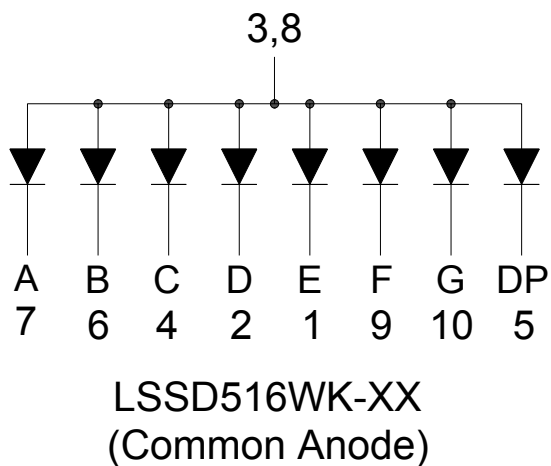
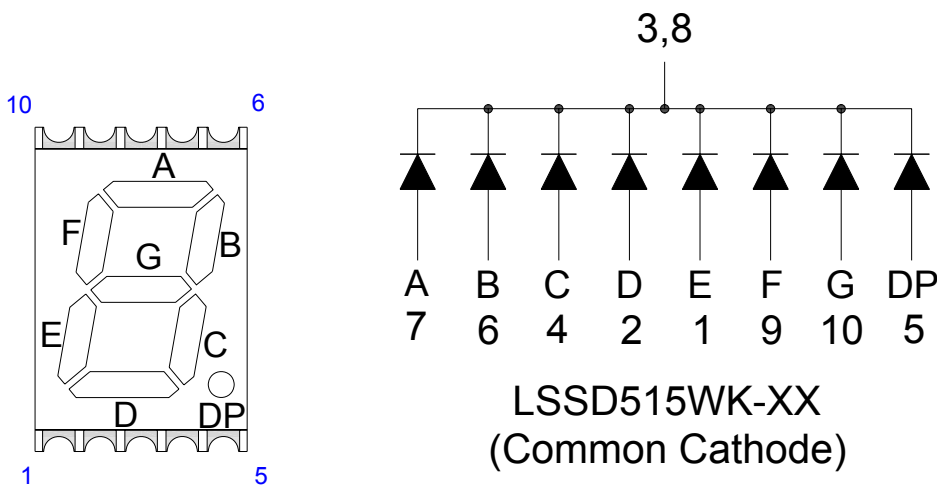

## Electrical Connection

PIN NO.	LSSD515WK-XX	PIN NO.	LSSD516WK-XX
1	Anode E	1	Cathode E
2	Anode D	2	Cathode D
3	Common Cathode	3	Common Anode
4	Anode C	4	Cathode C
5	Anode DP	5	Cathode DP
6	Anode B	6	Cathode B
7	Anode A	7	Cathode A
8	Common Cathode	8	Common Anode
9	Anode F	9	Cathode F
10	Anode G	10	Cathode G

## Absolute Maximum Ratings at Ta=25°C

Parameter	Symbol	Ratings	UNIT
Power Dissipation	PD	64	mW
Peak pulse current Duty 1/10@10KHz	I <sub>FP</sub>	80	mA
Forward Current Per Chip	I <sub>F</sub>	20	mA
Storage Temperature	T <sub>stg</sub>	-40 ~ +90	°C
Operating Temperature	T <sub>opr</sub>	-30 ~ +85	°C

## Typical Electrical & Optical Characteristics (Ta=25°C)

Parameter	Symbol	Min.	Typ.	Max.	Unit	Condition
Luminous Intensity	IV	---	65	----	mcd	IF=20mA
Chromaticity Coordinates	X	----	0.29	----	----	IF=20mA
	Y	----	0.28	----	----	IF=20mA
Forward Voltage	VF	----	3.2	----	V	IF=20mA
Reverse Current	Ir	----	----	10	μA	VR=5V

Note : 1.The forward voltage data did not including  $\pm 0.1V$  testing tolerance.

2.The luminous intensity data did not including  $\pm 15\%$  testing tolerance.

## Typical Electro-Optical Characteristics Curve

(25 °C Free Air Temperature Unless Otherwise Specified)

WK: Super Bright white (InGaN/GaN) CURVE

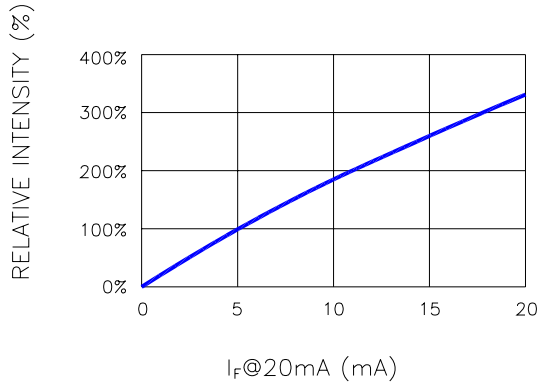

Fig.1 RELATIVE INTENSITY VS. FORWARD CURRENT

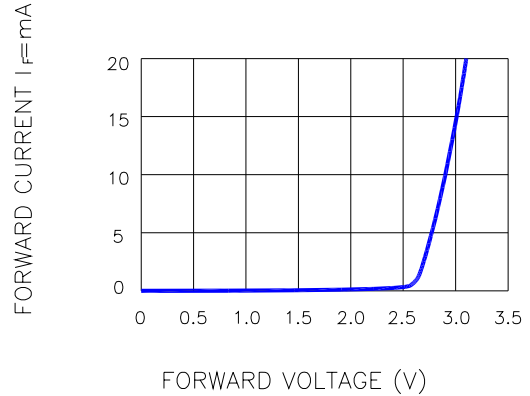

Fig.2 FORWARD CURRENT VS. FORWARD VOLTAGE

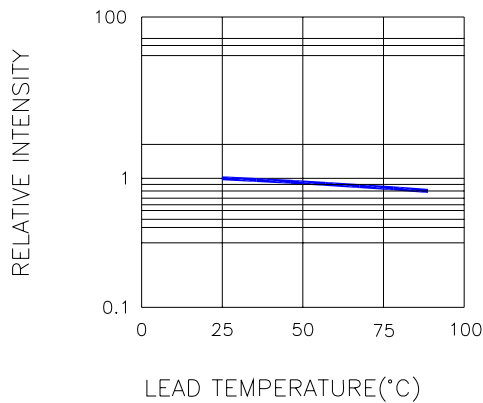

Fig.3 RELATIVE INTENSITY VS. LEAD TEMPERATURE  
(PULSED 20 mA; 300us PULSE, 10ms PERIOD)

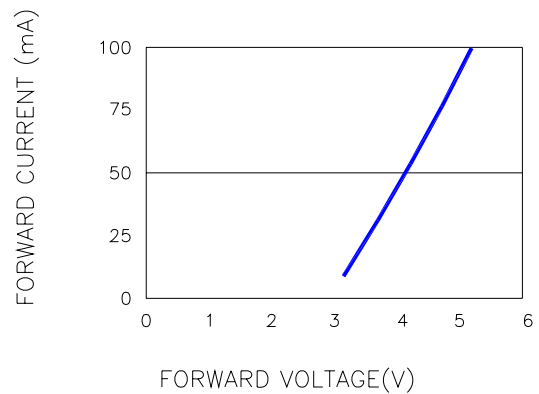

Fig.4 PEAK FORWARD VOLTAGE VS. FORWARD (100us TEST PULSE, 1% DUTY CYCLE)

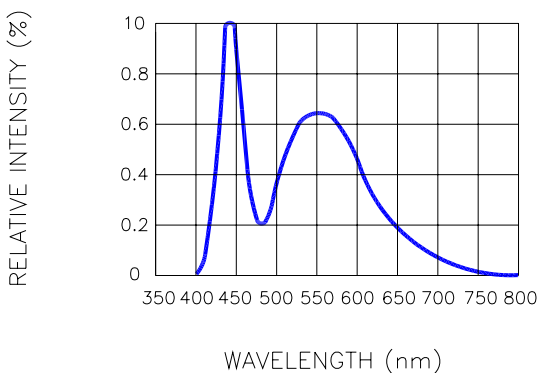

Fig.4 RELATIVE INTENSITY VS. WAVELENGTH

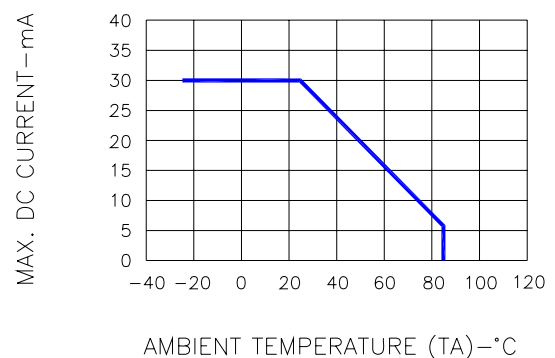
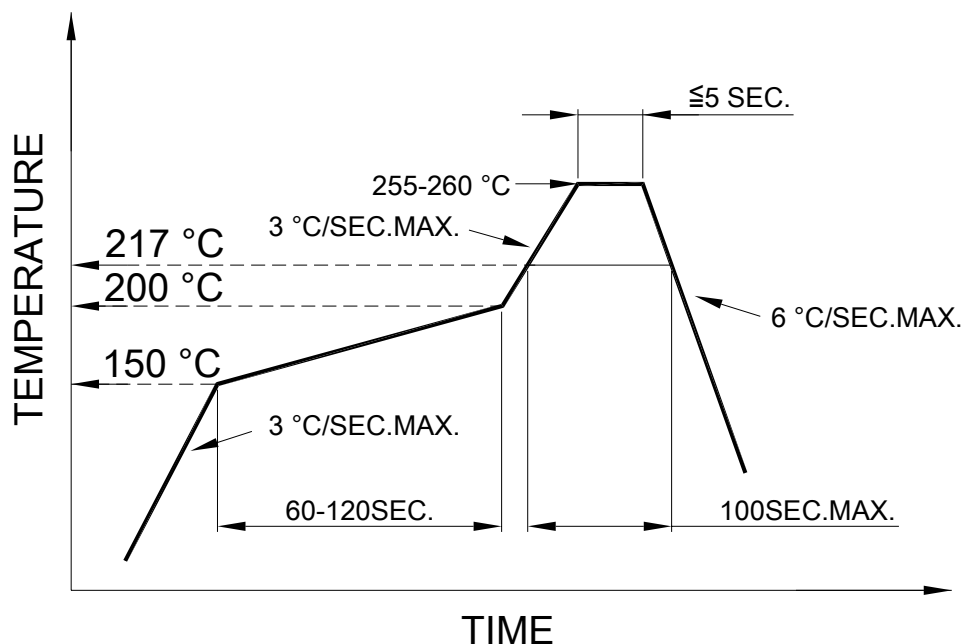

Fig.7 MAX. ALLOWABLE DC CURRENT VS. AMBIENT TEMPERATURE

## SMT REFLOW SOLDERING INSTRUCTIONS

SMT Soldering Profile

Pb free reflow soldering Profile



## SOLDERING IRON

Basic spec is  $\leq 4$  sec when 260°C. If temperature is higher, time should be shorter (+10°C→1 sec). Power dissipation of Iron should be smaller than 15W, and temperature should be controllable. Surface temperature of the device should be under 230°C.

## REWORK

Customer must finish rework within 3 sec. under 350°C.

The head of soldering iron cannot touch copper foil.